



DOCUMENTATION ISG-kernel

Functional description Axis collision monitoring

Short Description:
FCT-C3

© Copyright
ISG Industrielle Steuerungstechnik GmbH
STEP, Gropiusplatz 10
D-70563 Stuttgart
All rights reserved
www.isg-stuttgart.de
support@isg-stuttgart.de

Documentation version: 1.03
07/11/2024

Preface

Legal information

This documentation was produced with utmost care. The products and scope of functions described are under continuous development. We reserve the right to revise and amend the documentation at any time and without prior notice.

No claims may be made for products which have already been delivered if such claims are based on the specifications, figures and descriptions contained in this documentation.

Personnel qualifications

This description is solely intended for skilled technicians who were trained in control, automation and drive systems and who are familiar with the applicable standards, the relevant documentation and the machining application.

It is absolutely vital to refer to this documentation, the instructions below and the explanations to carry out installation and commissioning work. Skilled technicians are under the obligation to use the documentation duly published for every installation and commissioning operation.

Skilled technicians must ensure that the application or use of the products described fulfil all safety requirements including all applicable laws, regulations, provisions and standards.

Further information

Links below (DE)

<https://www.isg-stuttgart.de/produkte/softwareprodukte/isg-kernel/dokumente-und-downloads>

or (EN)

<https://www.isg-stuttgart.de/en/products/softwareproducts/isg-kernel/documents-and-downloads>

contains further information on messages generated in the NC kernel, online help, PLC libraries, tools, etc. in addition to the current documentation.

Disclaimer

It is forbidden to make any changes to the software configuration which are not contained in the options described in this documentation.

Trade marks and patents

The name ISG®, ISG kernel®, ISG virtuos®, ISG dirigent® and the associated logos are registered and licensed trade marks of ISG Industrielle Steuerungstechnik GmbH.

The use of other trade marks or logos contained in this documentation by third parties may result in a violation of the rights of the respective trade mark owners.

Copyright

© ISG Industrielle Steuerungstechnik GmbH, Stuttgart, Germany.

No parts of this document may be reproduced, transmitted or exploited in any form without prior consent. Non-compliance may result in liability for damages. All rights reserved with regard to the registration of patents, utility models or industrial designs.

General and safety instructions

Icons used and their meanings

This documentation uses the following icons next to the safety instruction and the associated text. Please read the (safety) instructions carefully and comply with them at all times.

Icons in explanatory text

- Indicates an action.
- ⇒ Indicates an action statement.



DANGER

Acute danger to life!

If you fail to comply with the safety instruction next to this icon, there is immediate danger to human life and health.



CAUTION

Personal injury and damage to machines!

If you fail to comply with the safety instruction next to this icon, it may result in personal injury or damage to machines.



Attention

Restriction or error

This icon describes restrictions or warns of errors.



Notice

Tips and other notes

This icon indicates information to assist in general understanding or to provide additional information.



Example

General example

Example that clarifies the text.



Programming Example

NC programming example

Programming example (complete NC program or program sequence) of the described function or NC command.



Release Note

Specific version information

Optional or restricted function. The availability of this function depends on the configuration and the scope of the version.

Table of contents

Preface	2
General and safety instructions	3
1 Overview	6
2 Description	7
3 Examples	11
4 Parameter	15
4.1 Overview.....	15
4.2 Description.....	15
5 Appendix	19
5.1 Suggestions, corrections and the latest documentation.....	19
Keyword index	20

List of figures

Fig. 1:	Three slides on one linear drive	7
Fig. 2:	6-axis parallel kinematic machine.....	8
Fig. 3:	Possible collision scenarios.....	10
Fig. 4:	Minimum permitted distance between a collision pair	11
Fig. 5:	Collision pair with 2 channels and mechanically inverted motion directions	11
Fig. 6:	Collision pair with different zero positions	12
Fig. 7:	Configuration of 2 collision pairs.....	13

1 Overview

Task

Mechanical collision of feed units whose motion ranges overlap is prevented by the axis collision monitoring function (collision monitoring). The motion ranges here run in parallel.

Characteristics

If a configurable limit is exceeded, the CNC generates an error message and the axes are stopped.

The collision monitoring function is used for gantry machines with linear drives with 2 or more slides or strut kinematic machines.

Parametrisation

The position monitor is configured for each individual axis in the axis parameter list. A complete list of parameters described in this document is contained in the chapter Parameters [▶ 15].

Mandatory note on references to other documents

For the sake of clarity, links to other documents and parameters are abbreviated, e.g. [PROG] for the Programming Manual or P-AXIS-00001 for an axis parameter.

For technical reasons, these links only function in the Online Help (HTML5, CHM) but not in pdf files since pdfs do not support cross-linking.

2 Description

Task

When collision monitoring is used, the position command values of an axis pair generated in the CNC are monitored.

If the distance between two positions undershoots the minimum permitted value with regard to the deceleration distance required for stopping,

- the axes stop immediately depending on the specified dyn. data and
- the CNC outputs the message P-ERR-70092.

After CNC RESET, the two axes must be positioned apart from each other.

Two axes for which the distance is monitored are referred to as a collision pair.

Several collision pairs may be formed.

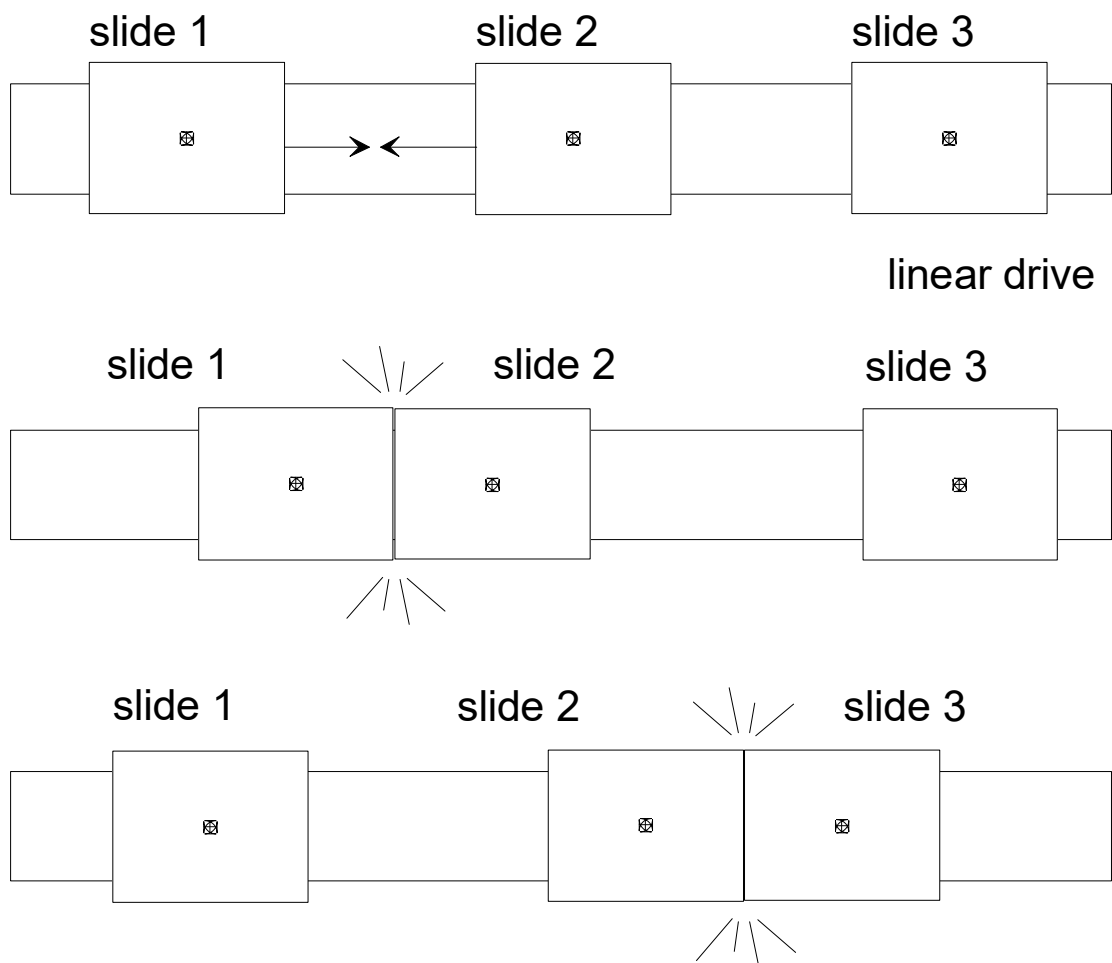

Fig. 1: Three slides on one linear drive

Besides machines with linear drive, collision monitoring is also used for machine with strut kinematics to monitor column slides for collisions.

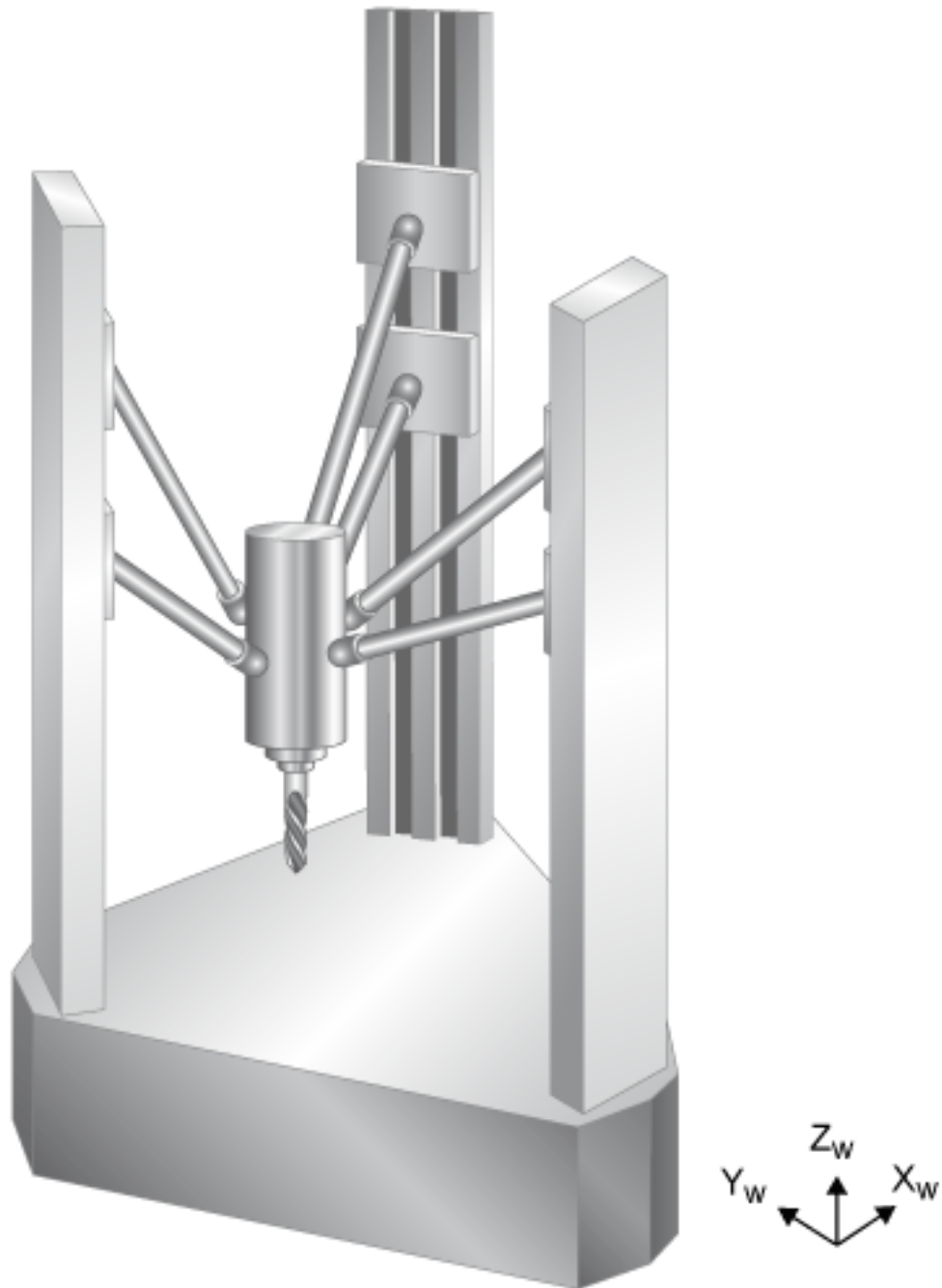

Fig. 2: 6-axis parallel kinematic machine



Attention

If the axes are shut down when a collision is detected, the programmed contour is normally exited.

Configuration

In the parameter P-AXIS-00015 (achs_mode) the 0x8000 bit is set for the two axes in a collision pair. The collision monitor is then active.

Additional data must be set for collision monitoring in one of the two axes of a collision pair. Normally the following inputs are set in the second axis of a collision pair, referred to as the master axis:

- In P-AXIS-00043 (coll_check_ax_nr) the logical axis number of the collision partner.
- In P-AXIS-00045 (coll_offset) the minimum permitted distance between slide reference points.

This type of configuration is no longer recommended: Due to downwards compatibility, two axes can be configured as collision partners. In this case the two collision distances P-AXIS-00045 (coll_offset) have the same value.

If the collision axes are in different CNC channels, the parameter P-AXIS-00044 (coll_decelerate_chan) can force a stop in the two channels if a collision axis reports a drive error.



Notice

The corresponding axes must first be referenced. Only then is the collision monitor active.

Axis deceleration for collision monitoring

By default the value of P-AXIS-00008 (a_max) is used for collision monitoring to calculate deceleration distances and stop the axes if a collision is detected.

The parameter P-AXIS-00267 (coll_use_a_emergency) can be used to change this deceleration to the value defined in P-AXIS-00003 (a_emergency).

Deceleration distance monitoring

The current velocity of an axis results from:

$$v_t = (\text{sollw}_{in} - \text{sollw}_{in-1}) / T_A$$

where:

v_t	current velocity
T_A	interpolation cycle time
sollw	position setpoints in cycles n and n-1

The minimum deceleration distance results from the deceleration set for collision monitoring by:

- P-AXIS-00008 (a_max),
- P-AXIS-00267 (coll_use_a_emergency),
- P-AXIS-00003 (a_emergency)

and the current velocity at:

$$s_{\text{brems}} = \frac{1}{2} (v_t^2 / a_{\text{coll}})$$

where:

s_{brems}	Deceleration distance
v_t	current speed
a_{coll}	Deceleration for collision monitoring

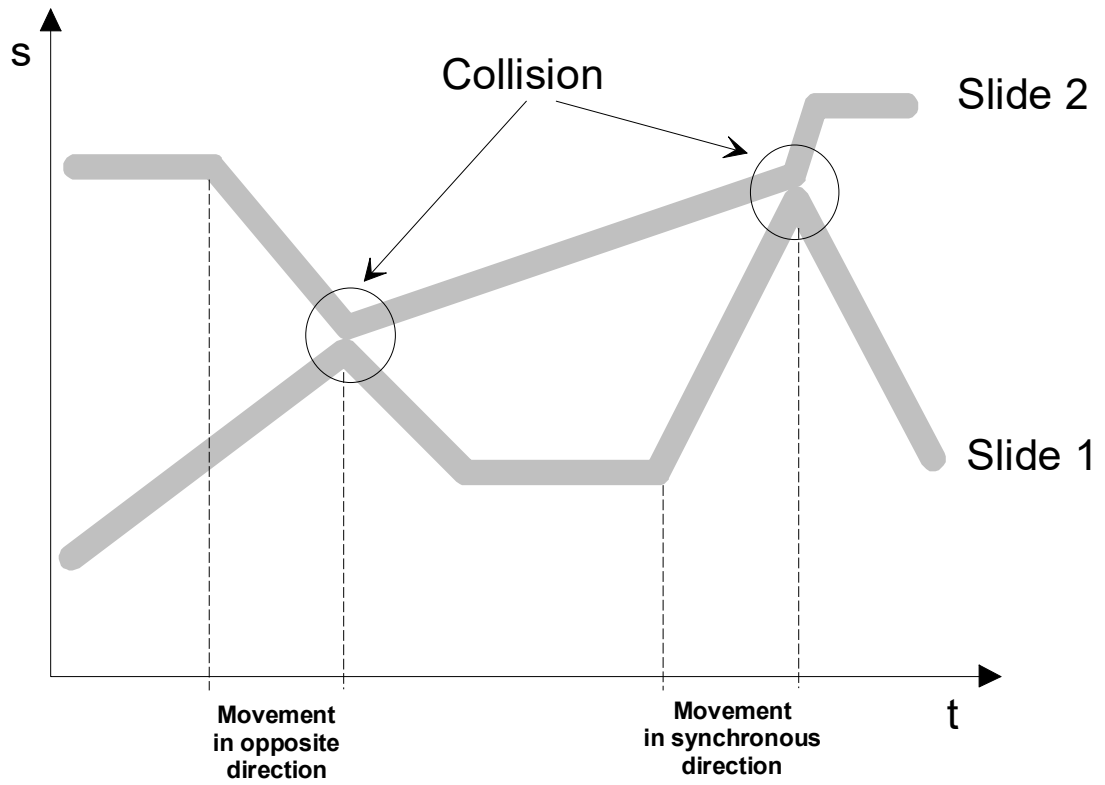

Fig. 3: Possible collision scenarios

3 Examples

Minimum permitted distance

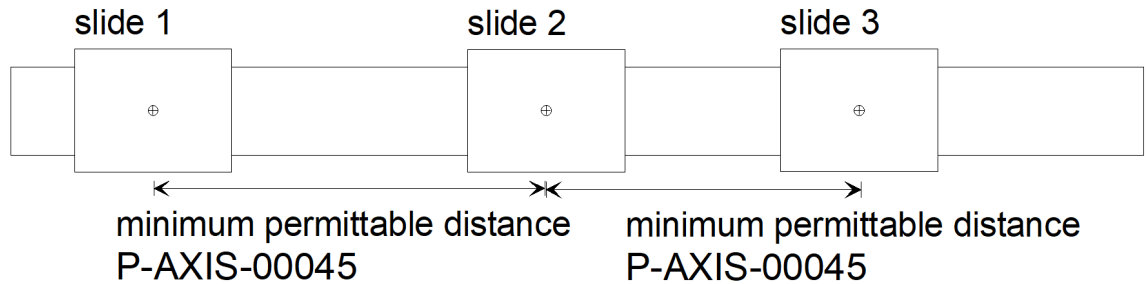

Fig. 4: Minimum permitted distance between a collision pair



Programming Example

Minimum permitted distance between a collision pair

Initialisation in the axis parameter list of X1

```
kopf.achs_nr      1
kenngr.achs_mode 0x8001
```

Initialisation in the axis parameter list of X2 (collision partner of X1)

```
kopf.achs_nr      2
kenngr.achs_mode  0x8001

kenngr.coll_check_ax_nr  1
kenngr.coll_offset      200000
```

Axis motion direction

The collision monitor assumes that the axes affected move in the same direction. If a motion in positive direction was programmed for the two axes in a collision pair, the axes also move mechanically in the same direction.

If this precondition is not fulfilled, it must be displayed in P-AXIS-00262 (coll_moving_dir_inverted) of the master axis.

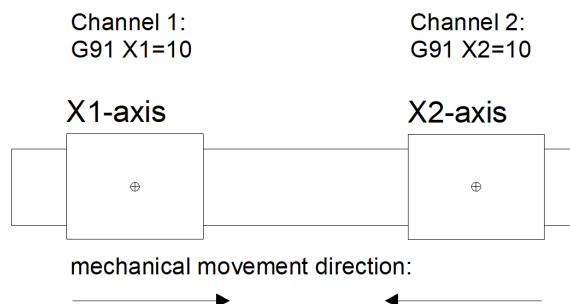

Fig. 5: Collision pair with 2 channels and mechanically inverted motion directions



Programming Example

2-channel collision pair with mechanically inverted motion directions

Channel 1:

Initialisation in the axis parameter list of X1

```
kopf.achs_nr           1
kenngr.achs_mode      0x8001
```

Channel 2:

Initialisation in the axis parameter list of X2 (collision partner of X1)

```
kopf.achs_nr           6
kenngr.achs_mode      0x8001

kenngr.coll_check_ax_nr  1
kenngr.coll_offset     200000
kenngr.coll_moving_dir_inverted 1
kenngr.coll_decelerate_chan 1
```

Zero positions of the axes

If the collision axes do not have the same zero position, then enter the zero offset in P-AXIS-00263 (coll_zero_position_offset). The value of the P-AXIS-00263 is equal to the position of the zero position of the collision partner axis in the axis coordinate system of the master axis.

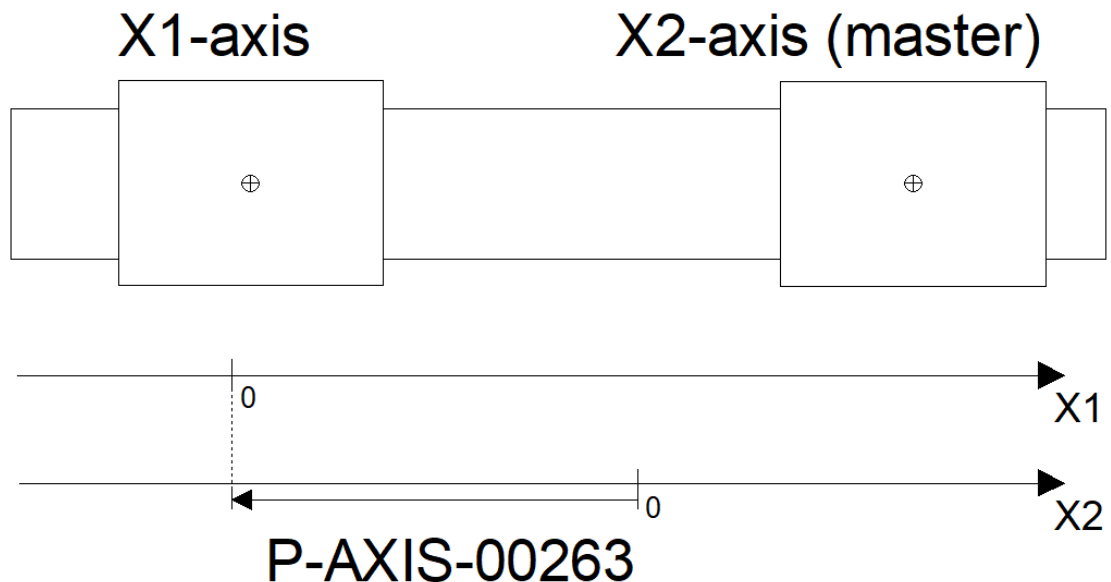

Fig. 6: Collision pair with different zero positions



Programming Example

Collision pair with different zero positions

Initialisation in the axis parameter list of X1

```

kopf.achs_nr           1
kenngr.achs_mode       0x8001
  
```

Initialisation in the axis parameter list of X2 (collision partner of X1)

```

kopf.achs_nr           2
kenngr.achs_mode       0x8001

kenngr.coll_check_ax_nr 1
kenngr.coll_offset     200000
kenngr.coll_zero_position_offset -1000000
  
```

Configuration of 2 collision pairs

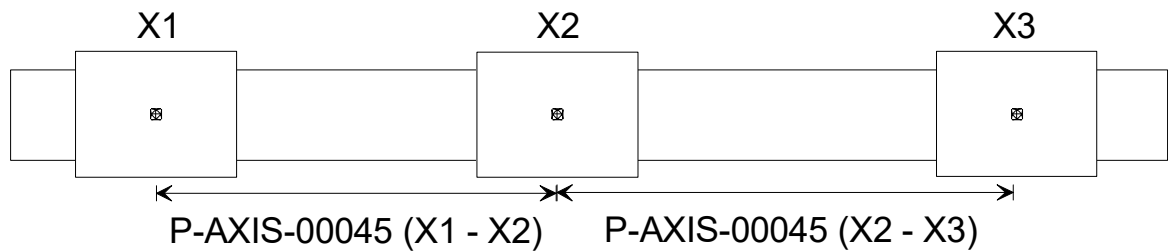

Fig. 7: Configuration of 2 collision pairs



Programming Example

Configuration of 2 collision pairs

This example defines two collision pairs (X1-X2, X2-X3):

Initialisation in the axis parameter list of X1

```
kopf.achs_nr          1
kenngr.achs_mode      0x8001
```

Initialisation in the axis parameter list of X2 (collision partner of X1)

```
kopf.achs_nr          2
kenngr.achs_mode      0x8001
```

```
kenngr.coll_check_ax_nr  1
kenngr.coll_offset      200000
```

Initialisation in the axis parameter list of X3 (collision partner of X2)

```
kopf.achs_nr          3
kenngr.achs_mode      0x8001
```

```
kenngr.coll_check_ax_nr  2
kenngr.coll_offset      300000
```

4 Parameter

4.1 Overview

ID	Parameter	Description
P-AXIS-00015	kenngr.achs_mode	Axis mode
P-AXIS-00043	coll_check_ax_nr	Logical number of the associated axis pair
P-AXIS-00044	coll_decelerate_chan	Stop collision axes in different channels
P-AXIS-00045	coll_offest	Minimum permitted position distance of the collision axes
P-AXIS-00262	coll_moving_dir_inverted	Collision axes have different mechanical motion directions
P-AXIS-00263	coll_zero_position_offset	Offset between zero positions of collision axes
P-AXIS-00267	coll_use_a_emergency	Execute collision monitoring with P-AXIS-00003 (a_emergency).

4.2 Description

P-AXIS-00015	Axis mode	
Description	Axes can be traversed in different operating modes.	
Parameter	kenngr.achs_mode	
Data type	UNS32	
Data range	0x00000001 - 0x10000000	
Axis types	T, R, S	
Dimension	T: ----	R,S: ----
Default value	0x00000001	
Drive types	----	
Remarks		

P-AXIS-00043	Monitoring of axis collision: Logical axis number	
Description	Logical axis number of the monitored axis. For this axis, the axis mode (P-AXIS-00015)) must be set to bit 0x8000.	
Parameter	kenngr.coll_check_ax_nr	
Data type	UNS32	
Data range	$1 \leq \text{coll_check_ax_nr} < \text{MAX}(\text{UNS32})$	
Axis types	T	
Dimension	T: ----	
Default value	0	
drive types.	----	
Remarks		

P-AXIS-00044	Monitoring of axis collision: Stopping in all channels during drive faults	
Description	<p>If collision axes are assigned to different channels, a stop in all channels can be forced by this parameter if one collision axis reports a drive error.</p> <p>This ensures that an error in the measurement system of an axis does not result in an axis collision.</p>	
Parameter	kenngr.coll_decelerate_chan	
Data type	BOOLEAN	
Data range	0/1	
Axis types	T	
Dimension	T: ----	
Default value	0	
drive types.	----	
Remarks		

P-AXIS-00045	Monitoring of axis collision: Security distance	
Description	Minimum distance between two collision axes.	
Parameter	kenngr.coll_offset	
Data type	UNS32	
Data range	$1 < \text{coll_offset} < \text{MAX}(\text{UNS32})$	
Axis types	T	
Dimension	T: 0.1µm	
Default value	0	
drive types.	----	
Remarks		

P-AXIS-00262	Monitoring of axis collision: Inverting of moving directions	
Description	If the axes of a collision pair at a programmed movement in the same direction move mechanically in different directions, this parameter must be set to 1.	
Parameter	kenngr.coll_moving_dir_inverted	
Data type	BOOLEAN	
Data range	0/1	
Axis types	T	
Dimension	T: ----	
Default value	0	
drive types.	----	
Remarks		

P-AXIS-00263	Monitoring of axis collision: Offset of zero positions	
Description	Enter a possible offset between the zero positions of the collision pair in this parameter. The offset value describes the position of the zero position of the collision partner in the axis coordinate system of the master axis.	
Parameter	kenngr.coll_zero_position_offset	
Data type	SGN32	
Data range	MIN(SGN32)<coll_zero_position_offset<MAX(SGN32)	
Axis types	T	
Dimension	T: 0.1µm	
Default value	0	
drive types.	----	
Remarks		

P-AXIS-00267	Monitoring of axis collision: Valid deceleration	
Description	By default, for collision monitoring P-AXIS-00008 (a_max) is used to calculate the braking distance and to decelerate the axis if a collision is detected. The parameter P-AXIS-00267 can determine that collision monitoring must be carried out with P-AXIS-00003 (a_emergency).	
Parameter	kenngr.coll_use_a_emergency	
Data type	BOOLEAN	
Data range	0/1	
Axis types	T	
Dimension	T: ----	
Default value	0	
drive types.	----	
Remarks		

5 Appendix

5.1 Suggestions, corrections and the latest documentation

Did you find any errors? Do you have any suggestions or constructive criticism? Then please contact us at documentation@isg-stuttgart.de. The latest documentation is posted in our Online Help (DE/EN):



QR code link: <https://www.isg-stuttgart.de/documentation-kernel/>

The link above forwards you to:

<https://www.isg-stuttgart.de/fileadmin/kernel/kernel-html/index.html>



Notice

Change options for favourite links in your browser;

Technical changes to the website layout concerning folder paths or a change in the HTML framework and therefore the link structure cannot be excluded.

We recommend you to save the above "QR code link" as your primary favourite link.

PDFs for download:

DE:

<https://www.isg-stuttgart.de/produkte/softwareprodukte/isg-kernel/dokumente-und-downloads>

EN:

<https://www.isg-stuttgart.de/en/products/softwareproducts/isg-kernel/documents-and-downloads>

E-Mail: documentation@isg-stuttgart.de

Keyword index

P

P-AXIS-00015	15
P-AXIS-00043	16
P-AXIS-00044	16
P-AXIS-00045	16
P-AXIS-00262	17
P-AXIS-00263	17
P-AXIS-00267	18



© Copyright
ISG Industrielle Steuerungstechnik GmbH
STEP, Gropiusplatz 10
D-70563 Stuttgart
All rights reserved
www.isg-stuttgart.de
support@isg-stuttgart.de

